

# CRUX

## Sous Vide Professional Style Cooker Instruction Manual

Styled for Life  
Designed & Engineered in New York City



## Table of Contents

Important Safeguards.....	4-6
Additional Important Safeguards.....	7-8
Grounded 3-Conductor Plug.....	8
Notes on the Cord.....	8
Plasticizer Warning.....	9
Electric Power.....	9
Life is Busy.....	9
Getting to Know Your CRUX Sous Vide Cooker.....	10
LED Display with Touchscreen Digital Controls.....	11
Start Up Guide with Temperature and Time Chart.....	12-17
Before Using for the First Time.....	18
Sous Vide Assembly.....	19
Operating Instructions.....	20-21
Auto Shut-Off.....	21
Hints & Tips for Sous Vide Cooking.....	22
USDA Cooking Guidelines.....	23
User Maintenance Instructions.....	23
Care & Cleaning Instructions.....	23
Descaling.....	23
Storing Instructions.....	24
Troubleshooting.....	25
Warranty.....	26-27

# IMPORTANT SAFEGUARDS

**WARNING: When using electrical appliances, basic safety precautions should always be followed, including the following:**

1. **READ ALL INSTRUCTIONS.**
2. **CAUTION:** The heating elements and removable stainless steel sleeve get hot during and after use. Do not touch any metal surface. The cooking container, water bath, and food pouches get hot during use. Use oven mitts or tongs when handling. Allow the Sous Vide Cooker to cool before emptying the water bath.
3. To protect against electrical shock do not immerse cord or plugs in water or other liquid.
4. This appliance is not intended for use by persons (including children) with reduced physical, sensory or mental capabilities, or lack of experience and knowledge, unless they have been given supervision or instruction concerning use of the appliance by a person responsible for their safety.
5. Close supervision is necessary when any appliance is used by or near children.
6. Unplug from outlet when not in use and before cleaning. Allow to cool before putting on or taking off parts.
7. Do not operate any appliance with a damaged cord or plug or after the appliance malfunctions, or has been damaged in any manner. Bring it to a qualified technician for examination, repair or for electrical or mechanical adjustment.

8. The use of accessory attachments not recommended by the appliance manufacturer may cause injuries.
9. Do not use outdoors.
10. Do not let cord hang over edge of table or counter, or touch hot surfaces.
11. Do not place on or near a hot gas or electric burner, or in a heated oven.
12. To disconnect, press the START/STOP button, then remove plug from wall outlet.
13. The Sous Vide Cooker is used to cook food only. Do not use appliance for other than intended use.
14. This Sous Vide Cooker is not intended to be operated by means of an external timer or separate remote control system
15. Never immerse the Sous Vide Cooker beyond the MAX water level mark. DO NOT immerse the LED display or handle. If the Sous Vide Cooker or any of these areas is submerged, immediately unplug the unit and contact customer service for assistance.
16. Food should be sealed in quality, heavy-duty zippered bags, special sous vide bags or canning jars before cooking in the hot water bath.
17. Time and temperature are critical in the cooking process because some bacteria can grow in food in the absence of oxygen and produce toxins. If food will not be consumed within 4 hours after sous vide cooking, cook until the food is pasteurized, or freeze for later use.

18. Extreme caution must be used when moving an appliance containing hot oil or other hot liquids.
19. Never operate the Sous Vide Cooker without the stainless steel sleeve securely locked over the heating elements.
20. Never operate the Sous Vide Cooker unless it is securely clamped to a sturdy vessel, such as a stock pot.
21. This Sous Vide Cooker is designed to be used to heat water only.

**FOR HOUSEHOLD USE  
ONLY**

**SAVE THESE  
INSTRUCTIONS**

# ADDITIONAL IMPORTANT SAFEGUARDS

**CAUTION HOT SURFACES:** This appliance generates heat and escaping steam during use. Proper precautions must be taken to prevent the risk of burns, fires or other injury to persons or damage to property.

1. A person who has not read and understood all operating and safety instructions is not qualified to operate this appliance. All users of this appliance must read and understand this instruction manual before operating or cleaning this appliance.
2. If this appliance falls or accidentally becomes immersed in water, unplug it from the wall outlet immediately. **Do not reach into the water!**
3. When using this appliance, provide adequate air space above and on all sides for air circulation. Do not operate this appliance while it is touching or near curtains, wall coverings, clothing, dishtowels or other flammable materials.
4. Do not leave this appliance unattended during use.
5. If this appliance begins to malfunction during use, immediately unplug the cord. Do not use or attempt to repair a malfunctioning appliance!
6. The cord to this appliance should be plugged into a 120V AC 3-prong electrical wall outlet.
7. Do not use this appliance in an unstable position. The working area must be flat and level.

8. Be careful when lifting the Sous Vide Cooker out of the hot water bath after cooking. Always lift the unit away from you as both the water bath and the unit are hot and can result in serious burns. Never place your face over the hot water bath or the unit.
9. Unplug the unit when not in use and before cleaning. Allow the Sous Vide Cooker to cool before putting on or taking off parts to clean.
10. The Sous Vide Cooker should NEVER contact food directly. Food products should NEVER come in contact with water bath. Food must be vacuum-sealed, heat sealed, or zip locked before use with the Sous Vide Cooker. Liquid food products like juice, soup or milk products need to be bagged or sealed in jars for sous vide cooking.

### **GROUNDING 3-CONDUCTOR PLUG**

This appliance is equipped with a grounded-type 3-wire cord (3-prong plug). This plug will only fit into an electrical outlet made for a 3-prong plug. This is a safety feature. If the plug should fail to fit the outlet, contact an electrician to replace the obsolete outlet. Do not attempt to defeat this safety feature.

### **NOTES ON THE CORD**

The provided short power-supply cord (or detachable power-supply cord) should be used to reduce the risk resulting from becoming entangled in or tripping over a longer cord. Do not use an extension cord with this product.



## PLASTICIZER WARNING

**CAUTION:** To prevent Plasticizers from migrating from the finish of the counter top or table top or other furniture, place NON-PLASTIC coasters or place mats between the appliance and the finish of the counter top or table top. Failure to do so may cause the finish to darken; permanent blemishes may occur or stains can appear.

## ELECTRIC POWER

If the electrical circuit is overloaded with other appliances, your appliance may not operate properly. It should be operated on a separate electrical circuit from other appliances.

## Life is Busy

Keep it simple in the kitchen with CRUX.

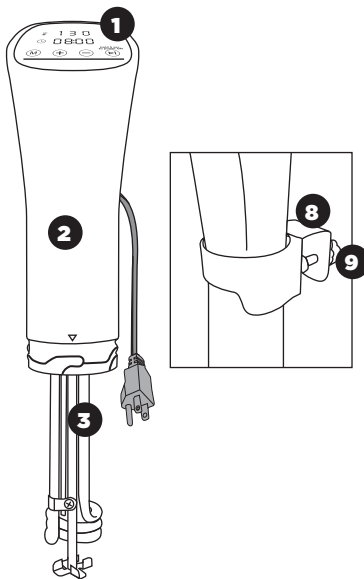
Sous vide has quickly become a culinary technique many home cooks now enjoy. Sous vide's rise in popularity is due to its simplicity and outstanding fool-proof results. The CRUX Sous Vide Cooker provides a precision temperature-controlled water bath in which vacuum or manually-sealed food is immersed and cooked low and slow, to perfection. Touchscreen digital control is easy-to-read, adjustable, and provides precise temperatures from 115°F to 195°F, **plus** a 10 minute to 72 hour timer. Pouches prevent evaporation and loss of flavor and nutrients, keeping foods moist, tender, and delicious. Intelligent water-level sensors turn heating elements OFF when taken out of water or when water level falls below the MIN mark.

Keep it simple in the kitchen with CRUX. Committed to efficiency, ease of use, and sleek design, our entire line of appliances was developed to make your life simpler. High quality products that get the job done, all while looking great on your countertop. It's never been easier to cook, host, or take on culinary adventures.

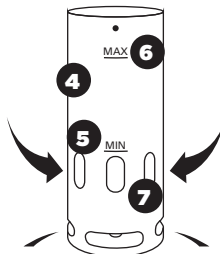
## Getting To Know Your CRUX Sous Vide Cooker

Product may vary slightly from illustration

1. LED Display with Touchscreen Digital Controls
2. Handle with Power Cord and 3-Prong Plug
3. Heating Elements
4. Removable Stainless Steel Sleeve
5. MIN Water Level
6. MAX Water Level
7. Water Circulation Ducts
8. Adjustable Stainless Steel Clamp Ring
9. Tightening Screw

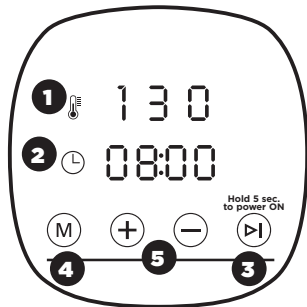


**Figure 1**



## LED Display with Touchscreen Digital Controls

Figure 2



1. **TEMPERATURE ICON / TEMPERATURE DISPLAY.** Backlighted digital TEMPERATURE display.
2. **TIME ICON / TIME DISPLAY.** Backlighted digital count down timer displays remaining TIME to 00:00.
3. **START/STOP Button.** When the START/STOP button is pressed for 5 seconds, the default TEMPERATURE/TIME 130°F / 08:00 hours will appear on the display.
4. **MODE (M) Button.** Press MODE(M) to change to TIME or TEMPERATURE. The active MODE will begin to flash.
5. **(+) or (-) Buttons.** Use the (+) or (-) buttons to adjust the cook TIME from 00:10 minutes to 2:00 hours in 1 minute increments; or from 2:00 hours to 72:00 hours in 30 minute increments. Use the (+) or (-) buttons to adjust the cook TEMPERATURE from 115°F to 195°F.

You can switch temperature display from Fahrenheit to Celsius before the unit starts pre-heating by pressing the 'M' button for 5 seconds. When the power cord is plugged-in, the default time and temperature of 08:00 hours and 130 deg F are displayed. You can press the M button for 5 seconds to switch between Fahrenheit to Celsius or vice versa. After the temperature display has been switched to the desired units you may continue to set desired cooking time and temperature.



### **THE ART OF SOUS VIDE COOKING:**

This method of cooking achieves perfectly cooked meals every time with no risk of over or under cooking. Gourmet chefs have used this technique to prepare everything from meat, to eggs and even fruits and vegetables for over a century. The sous vide cooking method retains all of the food's nutrients and juices making it healthier and tastier than traditional cooking methods. Now from the comfort of your own home, you too can cook like a professional chef, all that is needed is a sous vide immersion cooker, a resealable plastic bag and a pot of water.

### **PREPPING YOUR FOOD:**

Place food into a BPA-free resealable plastic bags. Add spices or condiments into the bag if desired (see Temperature and Time guide for some suggestions). When using spices and condiments a little bit goes a long way, experiment to find out your favorite seasonings and flavor intensities. You can also add a small amount of butter or oil to enhance flavor. It is important to remove as much air as possible from the bag **see page 20** for info on manual air removal.










### **FINISHING TOUCHES:**

Many chefs like to give meat a quick sear to add grill marks and a crisp outer texture. Heat a small amount of butter or oil in a hot skillet and sear for 30 seconds on each side. For more tips and hints **see page 22**.



## Sous Vide Temperature and Time Chart

### BEEF










		MIN		MAX
Steak	RARE 129°F / 54°	45min	 1.5hrs	3hrs
	MEDIUM RARE 136°F / 58°	45min	 1.5hrs	3hrs
	WELL DONE 158°F / 70°	45min	 1.5hrs	3hrs
Roast	RARE 133°F / 56°	5.5hrs	 7hrs	16hrs
	MEDIUM RARE 140°F / 60°	5.5hrs	 6hrs	14hrs
	WELL DONE 158°F / 70°	 5hrs		11hrs
Tough Cuts	RARE 136°F / 58°	 24hrs		48hrs
	MEDIUM RARE 149°F / 65°	 16hrs		24hrs
	WELL DONE 185°F / 85	6.5hrs	 8hrs	16hrs

Seasoning Suggestions: Crushed Garlic, Thyme, Shallots



## Sous Vide Temperature and Time Chart

### PORK

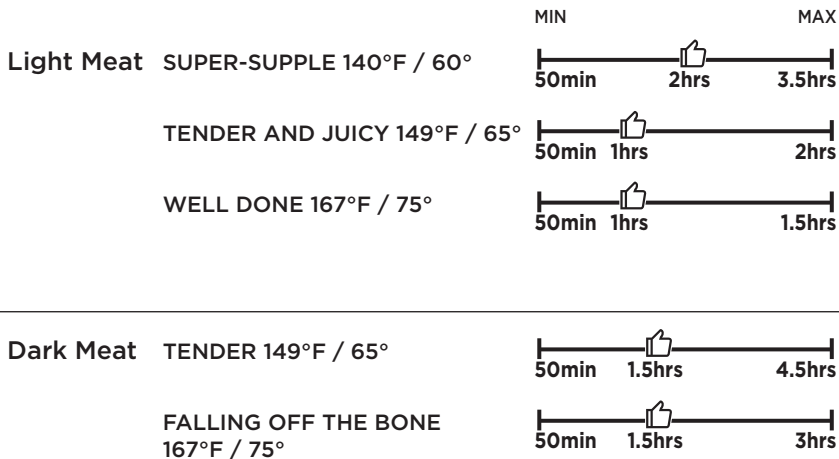
		MIN	MAX
Chop	RARE 136°F / 58°C	 1hr 2.5hrs	
	MEDIUM RARE 144°F / 62°C	 1hr 1.75hrs	
	WELL DONE 158°F / 70°C	 1hr 1.5hrs	
Roast	RARE 136°F / 58°C	 2.5hrs 3hrs 5.5hrs	
	MEDIUM RARE 144°F / 62°C	 2.5hrs 3hrs 4hrs	
	WELL DONE 158°F / 70°C	 2.5hrs 3hrs 3.5hrs	
Tough Cuts	RARE 144°F / 62°C	 10hrs 16hrs 24hrs	
	MEDIUM RARE 154°F / 68°C	 7hrs 12hrs 24hrs	
	WELL DONE 185°F / 85°C	 6.5hrs 8hrs 16hrs	

Seasoning Suggestions: Rosemary, Maple Syrup, Whole Grain Mustard



## Sous Vide Temperature and Time Chart

### CHICKEN

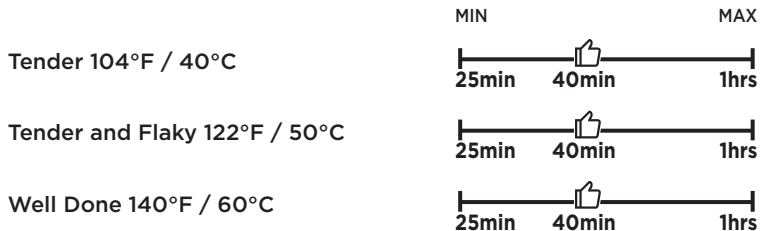


Seasoning Suggestions: Oregano, Garlic, Paprika



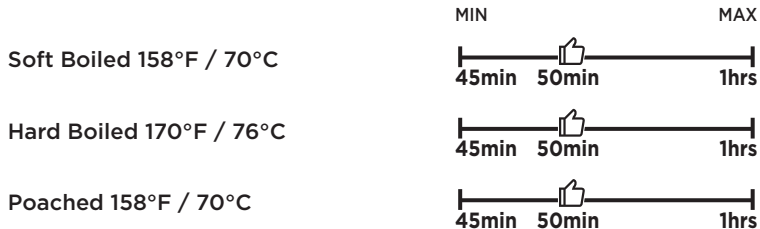
## Sous Vide Temperature and Time Chart

### FISH



Seasoning Suggestions: Lemon Slices, Dill, Lemon Thyme

### EGGS







## Sous Vide Temperature and Time Chart

### VEGETABLES

	MIN	MAX
Green Vegetables 185°F / 85°C	 10min ————— 20mins	
Winter Squash 185°F / 85°C	 1hr ————— 3hrs	
Potatoes & Root Vegetables 185°F / 85°C	 1hr ————— 3hrs	

Seasoning Suggestions: Rosemary, Basil, Chives

### FRUIT

	MIN	MAX
Warm & Ripe 154°F / 68°C	 1hr ————— 1.75hrs ————— 2.5hrs	
Cooked to Soft (for purées, etc.) 185°F / 85°C	 15min ————— 30mins ————— 1.5hrs	

Seasoning Suggestions: Cinnamon, Cloves, Nutmeg or Mint

## Before Using for the First Time

1. Carefully unpack your CRUX Sous Vide Cooker and discard all packaging materials. Your CRUX Sous Vide Cooker comes assembled and ready for use. Locate the stainless steel clamp and set aside for future use.

### 2. SOUS VIDE PREPARATION:

You will need:

**Figure 3**

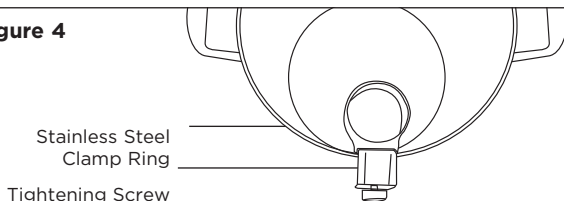


- A 6 to 20-quart pot or suitable container at least 6.5 inches deep
- High quality, BPA-free **HEAVY-DUTY ZIPPERED PLASTIC BAGS**, preferably gallon-sized, accommodate several servings of food. Perfect for: steak, fish, pork chops, chicken breasts, hamburgers.
- **Special BPA-Free SOUS VIDE BAGS** have strong seams that are specifically designed for higher temperatures. Special sous vide bags are necessary when braising meats for long periods of time or cooking vegetables such as lentils or beans at temperatures above 160°.
- **SOUS VIDE BAGS** are vacuum sealable, but **can be used by manually displacing water, then folding and clipping the bag opening** over the side of the pot.
- **For longer sous vide cooking times**, add water to the MAX water level. Periodically check on water level and add water as needed.
- This Sous Vide Cooker is equipped with an Auto Shut-Off safety device. Intelligent water-level sensors will immediately turn the heating elements OFF if the unit is removed from the water or if the water falls below the MIN water level.
- **CANNING JARS** should be used when cooking egg white bites, custards, curds, mousse, and yogurt.

## Sous Vide Assembly

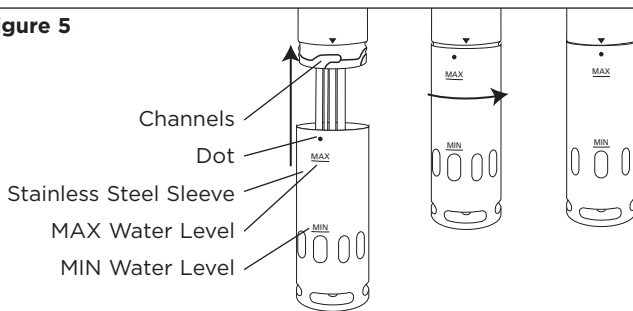
1. Place a 6 to 19 liter pot on a flat, level heat-proof surface.
2. Slide the top bracket of the adjustable stainless steel clamp over the side of the pot. Tighten the screw until the fit is secure.

**Figure 4**



3. Make sure the stainless steel sleeve is properly assembled over the heating element and onto the handle. Align the dot with the channel and turn the Sleeve clockwise to tighten.

**Figure 5**



4. Slide the stainless steel sleeve into the clamp ring, making sure the cord is facing the back of the unit into the electrical outlet.
5. Add water to the pot. Make sure the water level is between the MIN and MAX water level markings.

## Operating Instructions

1. Plug cord into a 120V AC 3-prong electrical wall outlet. The START/STOP button will begin to flash.
2. To program the Sous Vide Cooker, **press and hold** the START/STOP button for 5 seconds. The default temperature 130°F and 08:00 hours will appear on the display.
3. Press the MODE (**M**) button. An audible beep can be heard and the TEMPERATURE will begin to flash. Press the (+) or (-) buttons to adjust the cook TEMPERATURE from 115°F to 195°F.
4. Press the MODE (**M**) button. An audible beep can be heard and the TIME will begin to flash. Press and hold the (+) or (-) buttons to adjust the cook TIME from 00:10 minutes to 2:00 hours in 1 minute increments; or from 2:00 hours to 72:00 hours in 30 minute increments.
5. You can switch temperature display from Fahrenheit to Celsius before the unit starts pre-heating by pressing the 'M' button for 5 seconds. When the power cord is plugged-in, the default time and temperature of 08:00 hours and 130 deg F are displayed. You can press the M button for 5 seconds to switch between Fahrenheit to Celsius or vice versa. After the temperature display has been switched to the desired units you may continue to set desired cooking time and temperature.
6. When the correct target TEMPERATURE and TIME appear on the LED display, press the START/STOP button. An audible beep will be heard. In 10 seconds, **Pre** (PREHEAT) will appear on the LED display as water begins to circulate.
7. While the water is preheating, prepare food. Add herbs, seasonings or rubs to all foods before placing into cooking bags. Vacuum seal or remove air manually from the bag before cooking.
8. **Manual Air Removal** - The manual water displacement method works to remove air from plastic bags without the use of a vacuum sealer. This method is especially necessary when cooking softer foods such as hamburgers or chicken breasts, when the food product would lose its form using a vacuum sealer.
9. Fill a large plastic container with cool water. Prepare food to be cooked and place in a BPA-free plastic freezer bag. Do not seal.

10. Slowly immerse the food-filled bag into the water. This will force the air out as the bag is immersed. Continue immersing the bag until just before the water reaches the top of the bag. While still in the water, close or zip to seal, forcing out all remaining air as much as possible.

**IMPORTANT! Avoid overcrowding. Allow space around all food when sealing.**

**HINT!** To prevent bags from floating to the surface, when cooking light foods, add a small knife or spoon to the bottom of the bag before sealing.

**HINT!** Eggs in shells can be placed directly into the pot of water. Use resealable bags for cracked eggs.

11. When the target TEMPERATURE, appears on the LED display, **Pre** (PREHEAT) will disappear from the LED display, the colon (:) will flash as TIME begins to count down.
12. Add cooking bags or jars to the heated water bath. **For best results**, bags must be fully immersed in the water bath. Use clips to attach the tops of the bags to the top of the cooking pot for support and to avoid leakage.

**IMPORTANT:** You can add many bags as will fit in your cooking pot as long as there is adequate water circulation around each cooking bag.

13. When the TIME counts down to 00:00, the Sous Vide Cooker will automatically turn itself OFF: **End** and 4 dashes (- - -) will appear on the LED display. If you wish to begin a new cooking cycle press any button on the display, the START/STOP will begin to flash. Repeat process from step 2.
14. If cooking is completed unplug the Sous Vide cooker and allow to cool completely before cleaning.
15. Using oven mitts or tongs, carefully remove the cooking bags. Open carefully. Allow a few seconds for all steam to escape. Test food to make sure it is fully cooked.
16. Sear foods in a hot skillet or grill for a quick minute after sous vide cooking to achieve a crispy crust and brown color before serving.

**CAUTION:** Allow unit and water to cool before cleaning or storing.

## Auto Shut-Off

This Sous Vide Cooker is equipped with an Auto Shut-Off safety device. Intelligent water-level sensors will immediately turn the heating elements OFF if the unit is removed from the water or if the water falls below the MIN water level.

## Hints & Tips for Sous Vide Cooking

- To avoid water spots and calcification, and to ease cleaning stainless steel parts, prepare the water bath using soft/decalcified water.
- The thickness of meat, poultry and fish will determine the length of cooking time. Use an instant-read thermometer after removing from the cooking bag to guarantee that a safe-food temperature is achieved.
- Food safety in handling and cooking is always a priority. When unsure of doneness, add 30 minutes to the cook time to pasteurize eggs and/or poultry.
- Some tough cuts of beef and pork can be cooked sous vide to tender perfection in 4 to 24 hours.
- Vegetables cook faster if they are thinly sliced or cut into smaller pieces. Add cook time if vegetables are cooked whole.
- To prepare meat, poultry and fish before cooking, add herbs, seasonings or rubs before placing into the bag. Vacuum seal or remove air manually from the bag before cooking. Please see “Manual Air Removal” section of this instruction manual for a complete description.
- To prevent bags from floating to the surface, when cooking light foods, add a small knife or spoon to the bag before sealing.
- Eggs in shells can be placed directly into the pot of water. Use resealable bags for cracked eggs.
- **For best results**, brine chicken or fish for one hour in lightly salted water, drain and pat dry before seasoning and bagging.
- ALWAYS use BPA-free bags when cooking foods more than 8 hours.
- When cooking proteins, small or delicate foods sous vide, add oil to the cooking bag.
- **Avoid overcrowding. Allow space around all food when sealing.**
- You can have as many bags as will fit in your container that will still allow for adequate water circulation.
- After sous vide cooking is complete, sear foods for a quick minute to achieve a crispy crust and brown color.

## USDA Cooking Guidelines

**PLEASE NOTE:** The USDA recommends that meats such as beef and lamb, etc. should be cooked to an internal temperature of 145°F/63°C. Pork should be cooked to an internal temperature of 160°F/71°C and poultry products should be cooked to an internal temperature of 170°F/77°C - 180°F/82°C to be sure any harmful bacteria has been killed. When reheating meat/poultry products, they should also be cooked to an internal temperature of 165°F/74°C.

## User Maintenance Instructions

This appliance requires little maintenance. It contains no user serviceable parts. Do not try to repair it yourself. Any servicing requiring disassembly other than cleaning, must be performed by a qualified appliance repair technician.

## Care & Cleaning Instructions

**IMPORTANT!** To avoid water spots and calcification, and to ease cleaning stainless steel parts, prepare the water bath using soft, decalcified water.

**CAUTION:** The heating elements and removable stainless steel sleeve get hot during and after use. Unplug unit and allow the Sous Vide Cooker to cool. Remove unit from the stainless steel ring before emptying the water bath.

1. Always unplug and allow to cool completely before cleaning.
2. Wipe the handle with a soft, slightly damp cloth or sponge. Never use abrasive cleansers or scouring pads, as they may damage the surfaces.

## Descaling

1. After several uses, descaling may be required, particularly if hard water is used in cooking. Assemble the Sous Vide Cooker following the instructions described in “**Sous Vide Assembly**” section of this instruction manual.
2. Add one (1) ounce citric acid descaling powder (food grade) to the water.
3. Set the TEMPERATURE to 158°F and TIME for 20 minutes. When descaling is complete, press the START/STOP button to turn the unit OFF and unplug the unit.
4. When cool, rinse the area under the handle in clean, cool water. Wipe dry with a soft cloth.

## **Storing Instructions**

1. Be sure all parts are clean and dry before storing. Never store the Sous Vide Cooker while it is hot or wet.
2. Slide stainless steel clamp ring over the sleeve. Store Sous Vide Cooker in its box or in a clean, dry place.
3. Do not put any stress on cord where it enters unit, as this could cause cord to fray and break.



## Troubleshooting

<b>Problem:</b>	<b>Cause:</b>	<b>Solution:</b>
The START/STOP button is flashing but the LED display will not illuminate.	The unit has not been activated.	Press and hold the START/STOP button for 5 seconds.
The Sous Vide Cooker has turned itself OFF and E1 appears in LED display.	<ul style="list-style-type: none"><li>• The water pot has not been filled.</li><li>• The water level has fallen below the MINIMUM water level mark.</li><li>• The Sous Vide Cooker is not positioned on a flat surface.</li><li>• Electronics error.</li></ul>	<ul style="list-style-type: none"><li>• Unplug the Sous Vide Cooker. Add water past the MINIMUM water level mark. Plug into a 120V AC 3-prong electrical wall outlet. Press and hold the START/STOP button for 5 seconds to restart operation.</li><li>• Reposition unit on a clean, flat surface.</li><li>• Contact Consumer Service.</li></ul>
The Sous Vide Cooker has turned itself OFF and E4 appears in LED display.	<ul style="list-style-type: none"><li>• The water level has fallen below the MINIMUM water level mark.</li><li>• The overheat protection has been triggered.</li><li>• Electronics error.</li></ul>	<ul style="list-style-type: none"><li>• Unplug the Sous Vide Cooker. Add water past the MINIMUM water level mark. Plug into a 120V AC 3-prong electrical wall outlet. Press and hold the START/STOP button for 5 seconds to restart operation.</li><li>• Contact Consumer Service.</li></ul>

## Limited Two-Year Warranty

SENSIO Inc. hereby warrants that for a period of **TWO YEARS** from the date of purchase, this product will be free from mechanical defects in material and workmanship, and for 90 days in respect to non-mechanical parts. At its sole discretion, SENSIO Inc. will either repair or replace the product found to be defective, or issue a refund on the product during the warranty period.

The warranty is only valid for the original retail purchaser from the date of initial retail purchase and is not transferable. Keep the original sales receipt, as proof of purchase is required to obtain warranty validation. Retail stores selling this product do not have the right to alter, modify, or in any way revise the terms and conditions of the warranty.

### Exclusions:

The warranty does not cover normal wear of parts or damage resulting from any of the following: negligent use of the product, use of improper voltage or current, improper routine maintenance, use contrary to the operating instructions, disassembly, repair, or alteration by anyone other than qualified SENSIO Inc. personnel. Also, the warranty does not cover Acts of God such as fire, floods, hurricanes, or tornadoes.

SENSIO Inc. shall not be liable for any incidental or consequential damages caused by the breach of any express or implied warranty.

Apart from the extent prohibited by applicable law, any implied warranty of merchantability or fitness for a particular purpose is limited in time to the duration of the warranty. Some states, provinces or jurisdictions do not allow the exclusion or limitation of incidental or consequential damages, or limitations on how long an implied warranty lasts, and therefore, the above exclusions or limitations may not apply to you. The warranty covers specific legal rights which may vary by state, province and/or jurisdiction.


### **How To Obtain Warranty Service:**

You must contact Customer Service at our toll-free number: 1-866-832-4843. A Customer Service Representative will attempt to resolve warranty issues over the phone. If the Customer Service Representative is unable to resolve the problem, you will be provided with a case number and asked to return the product to SENSIO Inc. Attach a tag to the product that includes: your name, address, daytime contact telephone number, case number, and description of the problem.

Also, include a copy of the original sales receipt. Carefully package the tagged product with the sales receipt, and send it (with shipping and insurance prepaid) to SENSIO Inc.'s address. SENSIO Inc. shall bear no responsibility or liability for the returned product while in transit to SENSIO Inc.'s Customer Service Center.

# **CRUX**

For customer service questions or comments  
1-866-832-4843

For Recipes and Cooking tips  
[cruxkitchen.com](http://cruxkitchen.com)  
 [crux.kitchen](https://www.instagram.com/crux.kitchen)

CRUX is a trademark of 8479950 Canada Inc.  
All rights reserved.